

EACH OF 4 DAMPER PLATES (MAX), HELD IN PLACE BY INSTALLING AS SHOWN.

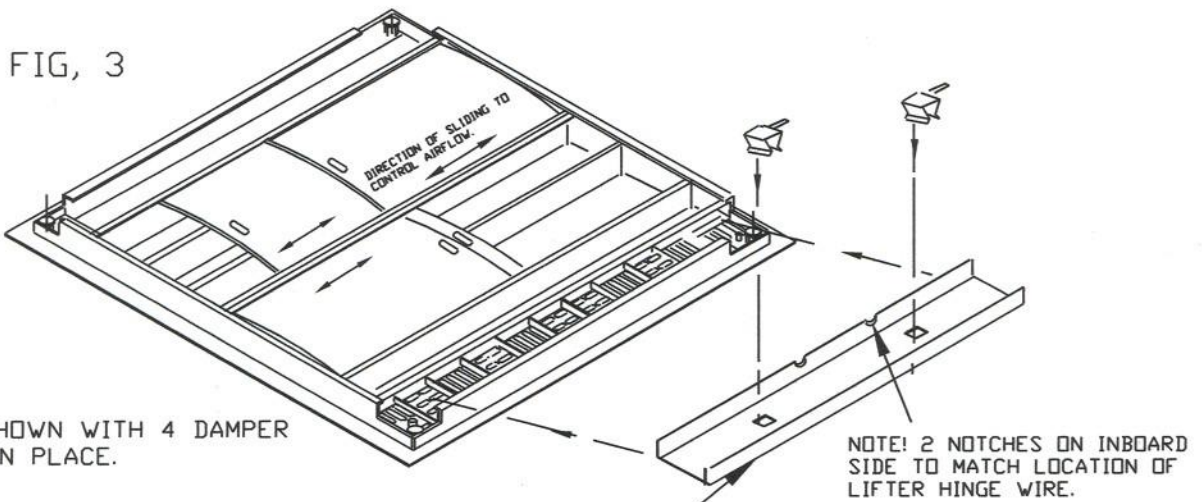

EACH OF 2 DAMPER SKIRTS HELD IN PLACE BY 2 RETAINER CLIPS

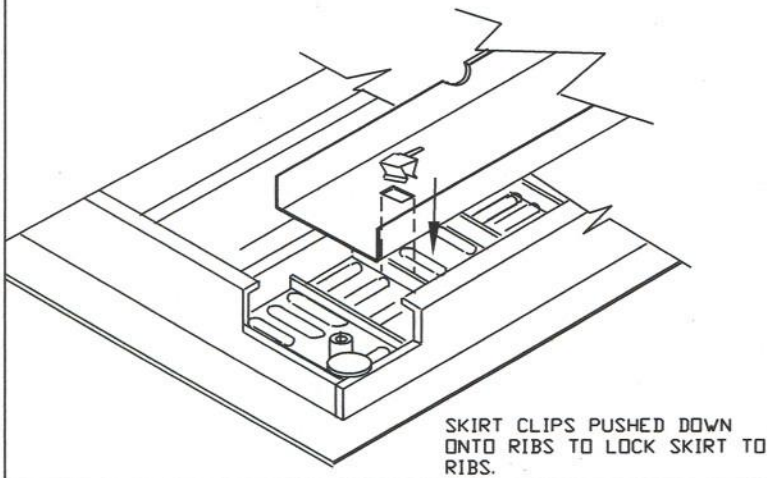

INFINITY GRATE.
ISOMETRIC VIEW OF
BOTTOM SURFACE. WITH DAMPER
AND SKIRT ASSEMBLY
INSTRUCTIONS.

10/4/06.